

# **CRAMARO**®

TARPAULIN SYSTEMS

## **ELECTRIC MOTOR OPTION INSTALLATION, MAINTENANCE, & SAFETY INSTRUCTIONS**

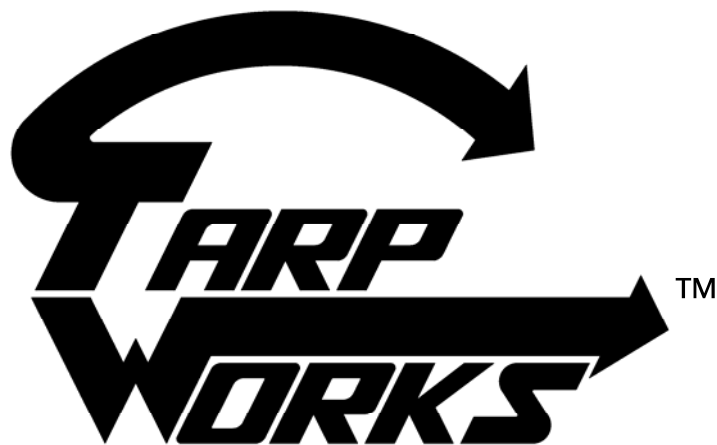

**(800) 272-6276**

**001-321-757-7611**

[www.cramarotarps.com](http://www.cramarotarps.com)

*Plants In: Delaware, Florida, Massachusetts, Nevada, Ohio, and Canada*

## Included in your kit will be:

1. Direct drive motor with cover.
2. Contact Plates (For full frame trailers).
3. Rocker switch and bracket (usually intended to be installed on the dash).
4. Solenoid/Relay kit.
5. Enough wire to do complete installation of motor kit. (Long/extended cabs may require purchase of additional wire).
6. Auto reset breaker.
7. Ring terminals for the attachment at the switch, solenoid/relay, motor and battery.
8. Quick disconnects if a trailer system.
9. Electric operation sticker..

## Automatic Reset Breaker Assembly for Direct Drive Motor

Breaker should be mounted inline on the positive side as close as possible to the battery. Attach a #10 ring terminal on the end of the switch wire to the breaker. On the other end of the breaker, attach a #10 ring terminal to the end for the breaker, and a 3/8" ring terminal to the other end for the battery terminal. The breaker should be mounted inline on the positive side as close as possible to the battery. Secure or protect the breaker from any possibility of short by covering with electrical tape.

NOTE: Attach "+" wire to battery terminal after all other install work is complete.

For Flip Style Tarping Systems, go to Step 1A.

For Slide Style Tarping Systems, go to Step 1B.

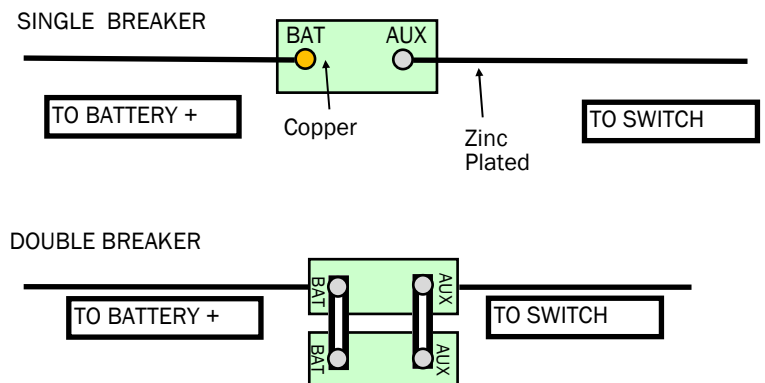

## Flip Style Tarping Systems (Step 1A)

Mount the electric roller plate with the large center hole matching up with the center hole of the passenger side roller plate and the (4) holes for the shield mount forward. Refer to the system installation instructions for the proper placement of the brackets.

Insert the output shaft of the motor through the large hole of the roller plate. Bolt motor to the plate using (3) 5/16" x 1" bolts with flat washers and lock washers. Bolt the output shaft of the motor through the predrilled hole in the roller tube using a 5/16" x 2 1/2" grade 5 hex bolt and nylock nut.

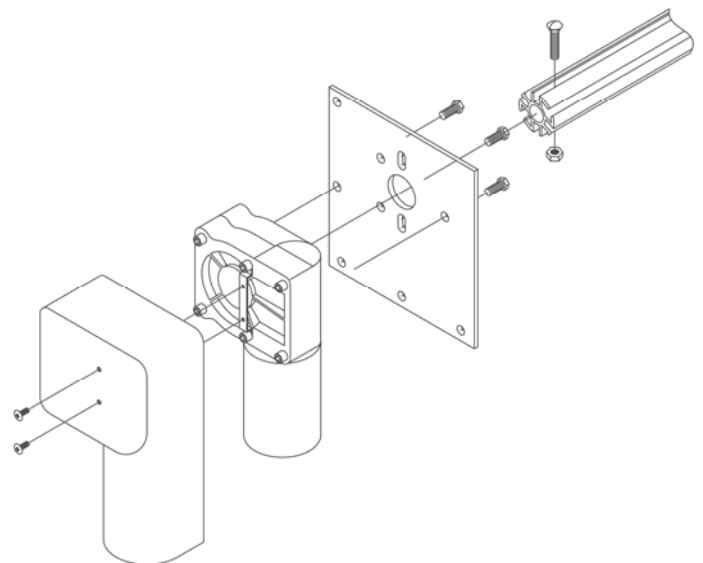

Proceed to Wiring Section.

## Slide Style Tarping Systems (Step 1B)

In your kit you will receive a shaft assembly with or without the steel 2x4 option. This assembly has one angle bracket that is longer to mount the electric motor. The bracket can be moved to the center if needed but care must be taken to move the large sprocket also. The bracket also allows mounting the motor in 3 positions, forward, down and backward.

CAUTION: Shaft bearings must be no more than 3" away from cable pulley.

NOTE: Do not remove tape from the motor only.

Mount the shaft assembly as per Slide And Go instruction manual (At the correct height and in the correct center position). The shaft assembly can be bolted or welded in position. The steel 2" x 4" option can also be utilized for radius trailers or to build an extension on the front as seen on some belly dump trailers. See system install manual. (The gearbox will be installed on the shaft. Motor portion ships separately to prevent damage. Once shaft has been affixed to the trailer, bolt the motor onto the gearbox. Ensure the slotted drive of the motor lines up with the gearbox. You may have to turn the slotted drive of the gearbox until it matches up.) Some motors have alignment guides located on the housing,, be sure all alignment guides match up.

Proceed to Wiring Section.

## Wiring

When splitting the duplex wire, always cut between the wires – do not pull the wire apart. Make sure there is no bare wire exposed.

Hook up wire to the motor using the ¼" terminal rings. Use enough wire to run from the motor, down frame of the trailer and over to the cab wire. Allow enough wire to go loosely around the pivot of the dump body so when the body is dumping, no wires will get pinched or torn.

Make sure to tie wire up to prevent drooping and damage.

OPTIONAL (used for full frame units)

If contact plates are supplied, run wire from motor down the body of the trailer to the top of the Upper Contact Plate. Placement of Contact Plates will be determined by the running of wire down from the motor. Take note that you have a limited amount of wire to find optimal placement of these plates. Then wire from the bottom of the Lower Contact Plate to the HD Quick Disconnect. See drawing in following pages for Contact Plate Installation.

**NOTE: DO NOT WELD ON MAIN FRAME**

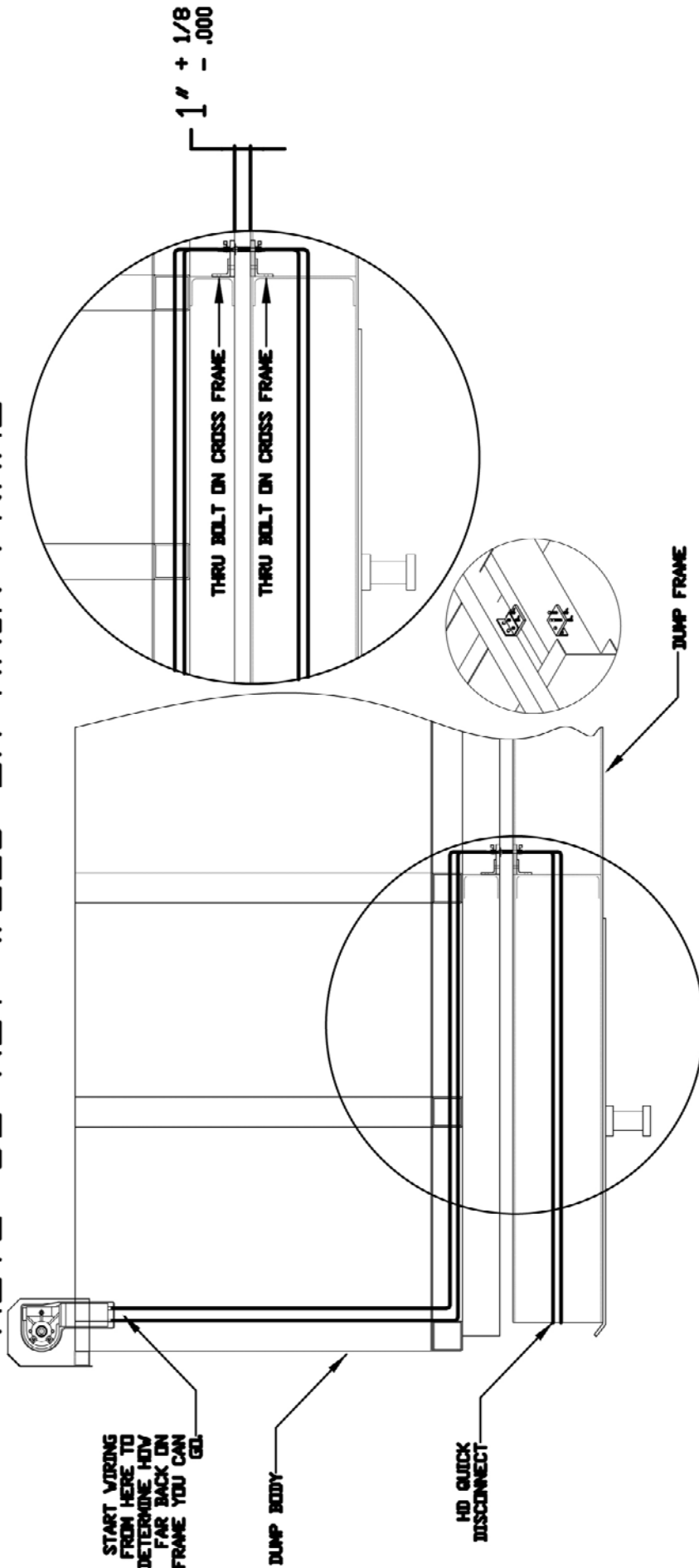

# SYSTEM WIRING DIAGRAM

**IMPORTANT!**

ALL COMPONENTS IN THE CIRCUIT MUST BE RATED AT THE SAME VOLTAGE AS THE BATTERY SOURCE

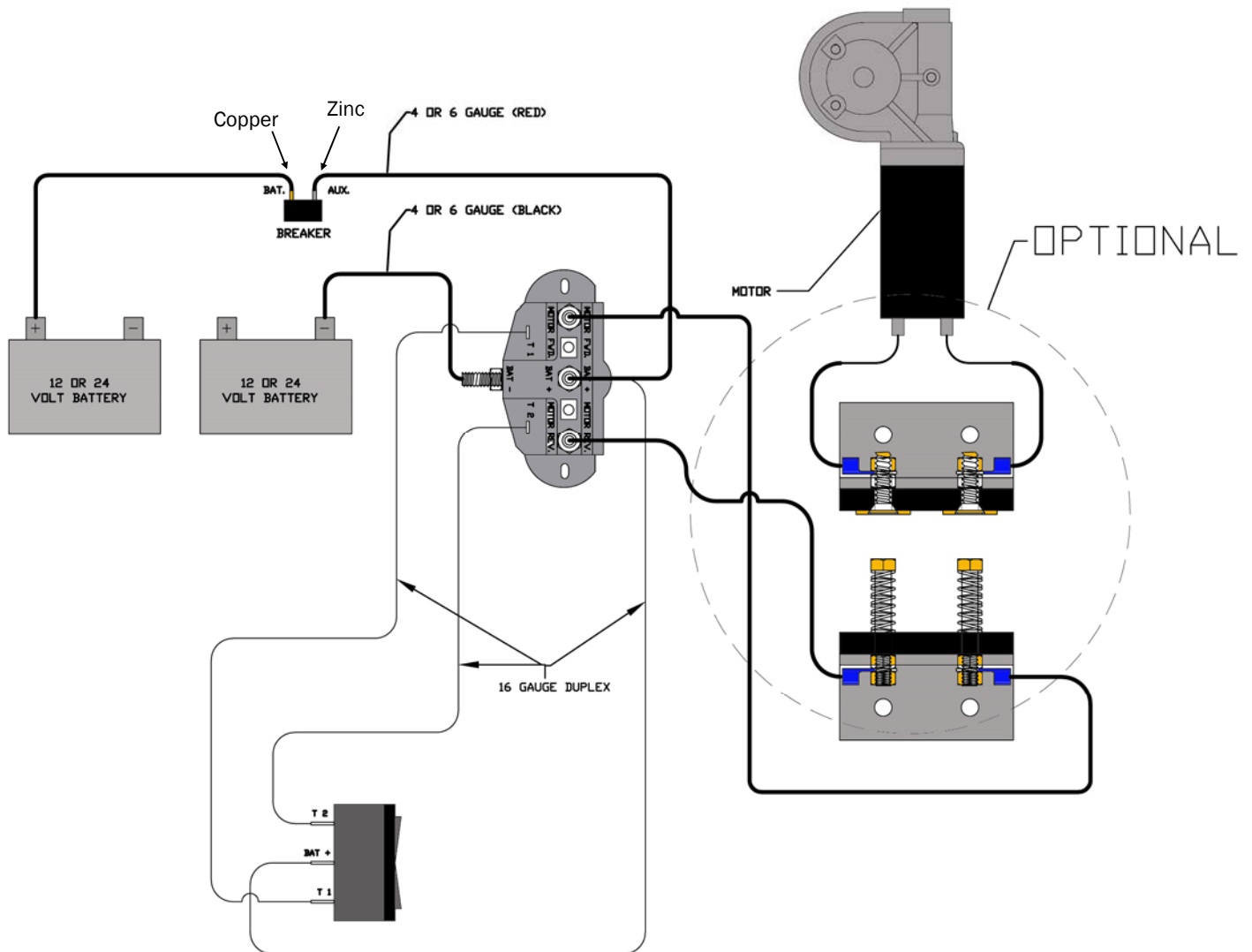

# DOUBLES WIRING DRAWING

\* ALL COMPONENTS IN THE CIRCUIT MUST BE RATED AT THE SAME VOLTAGE AS THE BATTERY SOURCE

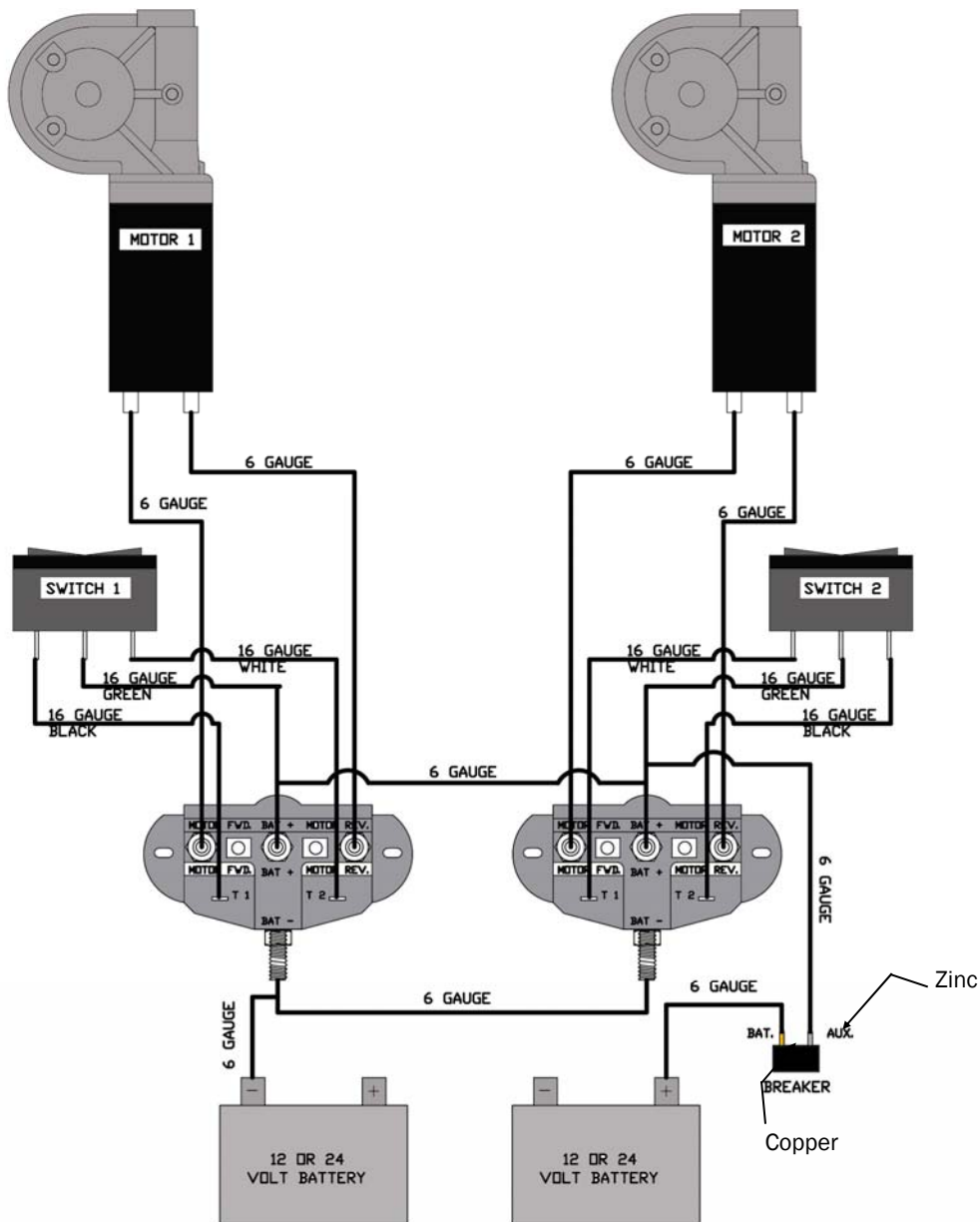



## Maintenance Instructions

1. Tighten any loose bolts and replace any worn parts immediately.
2. Inspect all wiring and connectors.
3. Inspect the front roller tube; if it is not rolling straight, it will create a strain on motor bearings and void the warranty.
4. Refer to the motor owner's manual for more information.

## Safety Precautions

1. Make certain installed properly.
2. Use appropriate safety procedures when installing.
3. Keep hands away from motor when in use.
4. Keep properly maintained.
5. Install guards and do not remove while operating.
6. Use proper tool for installing the ring terminals.
7. Always pay close attention to the system when operating. Let go of the switch as soon as the system is completely at the front or back. Failure to do so could cause damage to the motor, system, or body.

**If you require further information or assistance please, contact us at (800) 272-6276.**