

CRAMARO®

TARPAULIN SYSTEMS

LIFT 'N LOAD™

**INSTALLATION, MAINTENANCE,
& SAFETY INSTRUCTIONS**

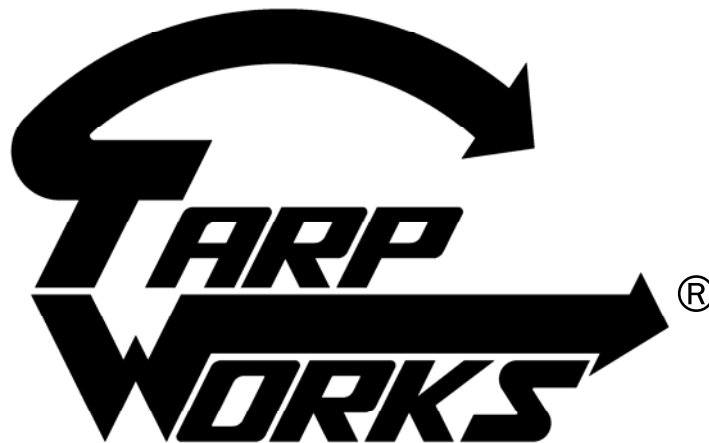

(800) 272-6276

001-321-757-7611

www.cramarotarps.com

Plants In: Delaware, Florida, Massachusetts, Nevada, Ohio, and Canada

General Information Prior to Install

- Trailers with center support above the top rail. Install the center hinge offset to either side of the brace. This should be done before measuring, cutting and assembling the ladder and center lid.
- Lid extensions should overhang top rail approximately 1" to 2". The completely assembled lid (with the tarp) should just overhang the top rail and the cable should NOT rest on the top rail.
- Cramaro Tarpaulin Systems supplies neither a fuse/circuit breaker nor installation instructions for inserting a fuse/circuit breaker between the 16' pigtail harness and the battery terminals. A fuse/circuit breaker installation is at the discretion and responsibility of the installer. If a fuse/circuit breaker is installed, we suggest a minimum of 125 amps.
- Applying Lock-Tite to the bolts holding the hinge pin assemblies and to the threads on the turnbuckles will help hold them in place.
- Caution: Actuator weighs approximately 90 lbs. USE CAUTION WHEN LIFTING! An eyebolt attached to top of actuator is for the use of a rope to assist with lifting in place.
- Caution: Failure to cycle hydraulic system 10 complete cycles prior to attaching actuator arm could result in equipment damage and/or personal injury.
- Caution: Before operating Lift-'N-Load tarp mechanism, ensure there are no power lines or other obstacles above trailer. Ensure there is adequate room along side of the trailer for the full width of the Lift-'N-Load as it rotates to the side of the trailer.
- Caution: Position Lift-'N-Load flush against side of trailer before loading. Ensure Lift-'N-Load is closed on top of trailer before moving trailer.
- Caution: Do not use a solid or heavy tarp on the Lift-'N-Load. The system was designed for use with the tarp supplied. The use of any other tarp may cause system failure or injury and void the warranty. If you need a replacement tarp, or have questions about using a different style tarp, please contact Cramaro Tarps at 1(800) 272-6276.
- Follow these instructions for proper installation of the Lift-'n-Load system.

Verify Parts Received Against Parts List Enclosed

- We have enclosed 1/2-13 nuts and washers for attaching equipment to the top rail of the trailer. Since all trailers require different lengths of bolts due to the various designs of the trailers it will be necessary to obtain 1/2-13 bolts long enough to bolt through the top and side of trailer. The places where you are unable to bolt through the trailer you will need to drill and tap a hole and use shorter bolts. Use a 27/64 drill bit vice the 9/16 drill bit if you need to tap the holes. You will need 10 bolts for the side, 2 bolts for the front, 9 bolts for the top of side, and 4 bolts for the top of front of the trailer walls.
- There are extra 1/2" washers in the bag labeled "miscellaneous" for use as spacers (if the trailer is not exactly square) when attaching the equipment to the top rail of trailer. These washers will need to be installed between the trailer and the equipment you are installing to make up for any gaps between them.
- If you have a steel trailer, then you can weld the equipment to the top rail of the trailer vice drilling holes and bolting in place. You will not have to disassembly the hinges when installing the corner mounting bracket, the center hinge, or the rear hinge.

PACKING LIST FOR Lift 'N Load

P/N	QTY	BALLOON	DESCRIPTION
1059	1		LIFT-N-LOAD COMPLETE SYSTEM
1048	1	1	ACTUATOR ASSEMBLY, 134 lb (60.9Kg)
803	1	2	ACTUATOR ARM ASSEMBLY
805	1		ACTUATOR ARM WELDMENT
756	2		1 1/2 ID x 2" (3.81cm ID x 5.04cm) BUSHING
810	1		1 1/4" ID x 2 1/2" (3.17cm ID x 6.35cm) BUSHING
811	2		1 1/2 ID x .047 THK (3.81cm ID x .12cm THK) SHIM
2589	5		1 1/2 (3.81cm) EXT RETAINING RING
784	2	3	SHORT LINK ASSEMBLY
1665	1		1" ID x 1" (2.54cm ID x 2.54cm) BUSHING
2587	1		1 1/2 ID x 1" (3.81cm ID x 2.54cm) BUSHING
796	1	4	LONG LINK ASSEMBLY
1665	1		1" ID x 1" (2.54cm ID x 2.54cm) BUSHING
2587	1		1 1/2 ID x 1" (3.81cm ID x 2.54cm) BUSHING
1196	1	5	ROLLER ASSEMBLY (10" SHAFT W/ ROLLER)
779	2		UHMW ROLLER
1188	2		ROLLER SHAFT (10")
812	1	6	HYD. CYLINDER
1055	1	7	WIND DEFLECTOR
1056	1		LARGE WIND DEFLECTOR BRACKET
1057	1		SMALL WIND DEFLECTOR BRACKET
4311	2	8	FRONT + REAR HINGE ASSEMBLY
4313	1	9	CENTER HINGE ASSY
1051	1	10	FRONT LID WELDMENT, 91 lb (41 Kg)
2594	1	11	REAR LID WELDMENT, 41 lb (18.6 Kg)
2597	1	12	CENTER LID WELDMENT
2601	6	13	LADDER WELDMENT, 22 lb (10 Kg)
3313	1		BOX OF 4 "H" CONNECTORS
2603	4	14	"H" CONNECTOR
3587	2	15	CABLE, 30' w/ TURNBUCKLE
2609	3	16	LID EXTENSION WITH OUT CABLE
2734			HYDRAULIC PUMP ASSY. 12V @ 2100psi (144.8 bar)
2532			HYDRAULIC PUMP 12V @ 2100psi (144.8 bar)
2779			HYDRAULIC PUMP ASSY. 24V @ 2100psi (144.8 bar)
2767			HYDRAULIC PUMP 24V @ 2100psi (144.8 bar)
1437			PUMP MOUNT BRACKET
2859	1		TARP, STANDARD LIFT-N-LOAD
3742			SOLENOID COVER

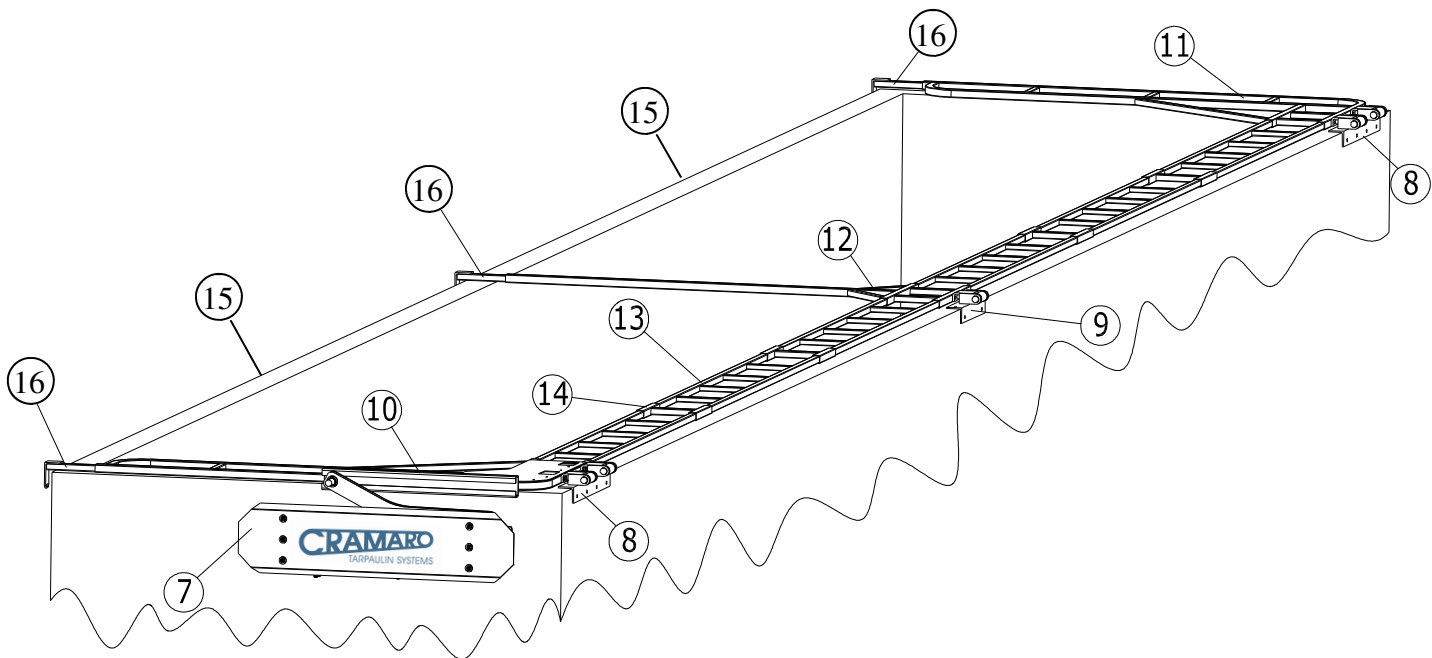
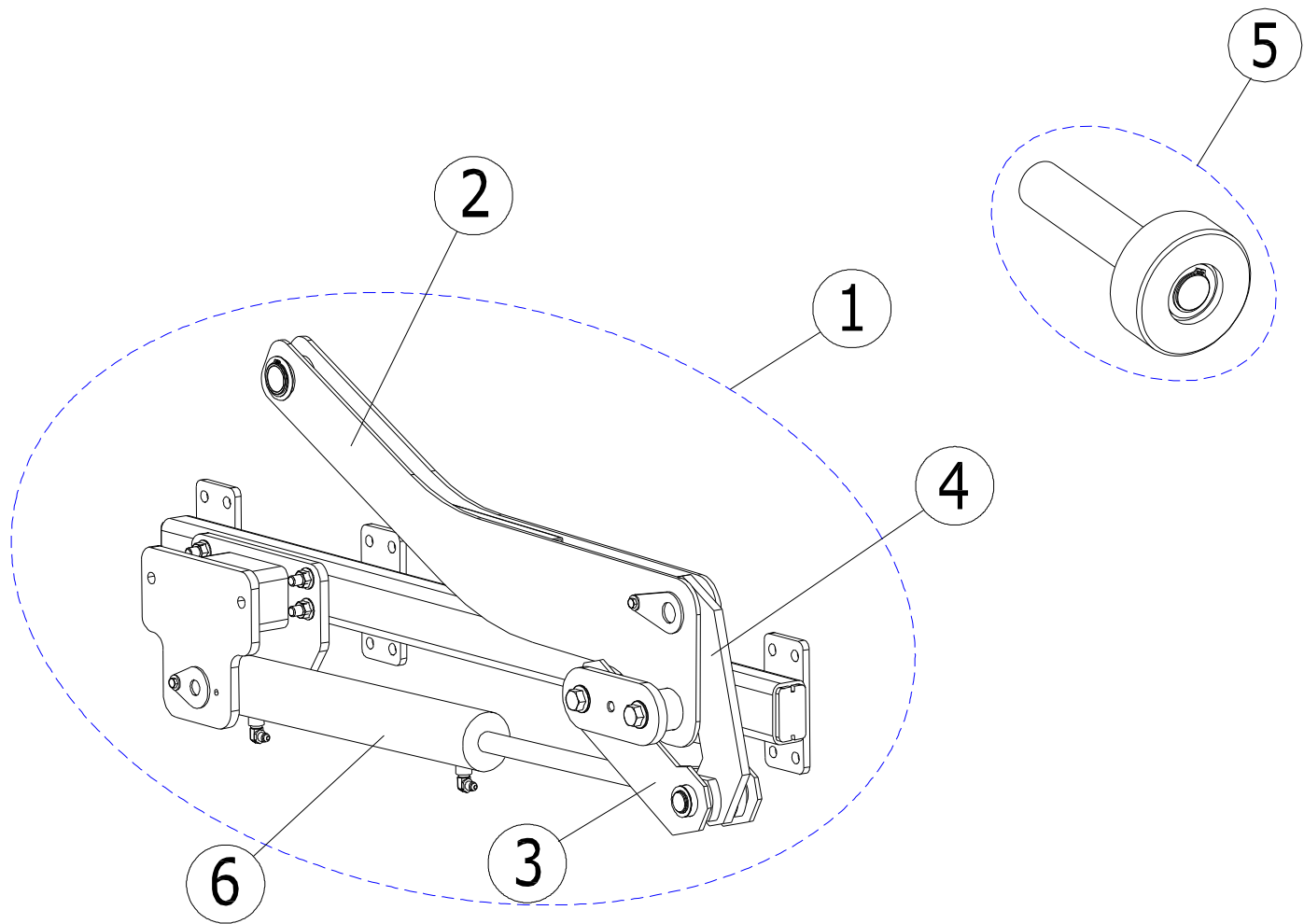

HARDWARE LIST FOR LIFT-N-LOAD

P/N	QTY	DESCRIPTION
2622	10	1/2-13 x 3, GR 5 FOR HINGE TO LID
2877	15	1/2-13 LOCK NUT FOR HINGE TO LID
2878	50	1/2 WASHERS FOR HINGE TO LID
916	3	1/2-13 x 2 LONG BOTTON HEAD, STAINLESS
1341	3	1/2-13 x 3 LONG BOTTON HEAD, STAINLESS
917	6	1/2 WASHER STAINLESS
2874	6	3/8-16 LOCK NUT
2875	10	3/8 WASHER
2464	4	3/8-16 X 1 1/2 LONG GR 5 BOLT
2579	4	3/16" CABLE NUT
2548	2	3/16" THIMBLE
2827	150	8" BLACK WIRE TIES, 120lbs
3299	20	1/4 x 3/4 SELF DRILLING SCREWS
2689	15	3/4" STEEL LOOP STRAP
3858	1	LOCTITE 262, .5ml
1144	10'	SPIRAL WRAP PE
SPLICE TAPE	6'	3M, SPLICING TAPE, 2"
4135	3	UHMW BUMPER STRIPS (INSTALLED ON LIDS WHERE THEY TOUCH THE TRAILER)
3325	2	1 1/2" ROUND RUBBER BUMPER (HYDRAULIC PUMP)

WET KIT OPTION

P/N	QTY	DESCRIPTION
3972		WET KIT COMPONENTS

NOTE: FOR COMPLETE LIST OF HARDWARE AND INSTALLATION SEE PAGE 19-21.

THESE INSTRUCTIONS SHOW THE SYSTEM BEING INSTALLED ON THE DRIVER SIDE OF THE TRAILER. FOLLOW THE SAME INSTRUCTIONS AND DIMENSIONS IF INSTALLATION IS TO BE ON THE PASSENGER SIDE.

1. PLACE ACTUATOR UNIT ON FRONT OF TRAILER AS SHOWN BELOW. USE THE (4) MOUNTING TABS AS A TEMPLATE, AND MARK THE HOLE LOCATION ON THE FRONT OF THE TRAILER
(IF THE TRAILER IS STEEL, THE UNIT COULD BE WELDED INTO PLACE. **NOTE: IF WELDING TO TRAILER USE EXTREME CAUTION TO AVOID GETTING WELD SPLATTER ON THE CHROME CYLINDER ROD. THIS WILL CAUSE PERMANENT DAMAGE TO THE CYLINDER AND VOID THE SYSTEMS WARRANTY).**)

NOTE: THE ACTUATOR UNIT WEIGHS 134 lb (61 Kg). USE A OVER HEAD LIFTING DEVICE, AND SLING TO LIFT INTO MOUNTING LOCATION. PLACE SLING AROUND ENTIRE UNIT AT LOCATION MARKED "LIFTING POINT" IN DRAWING BELOW.

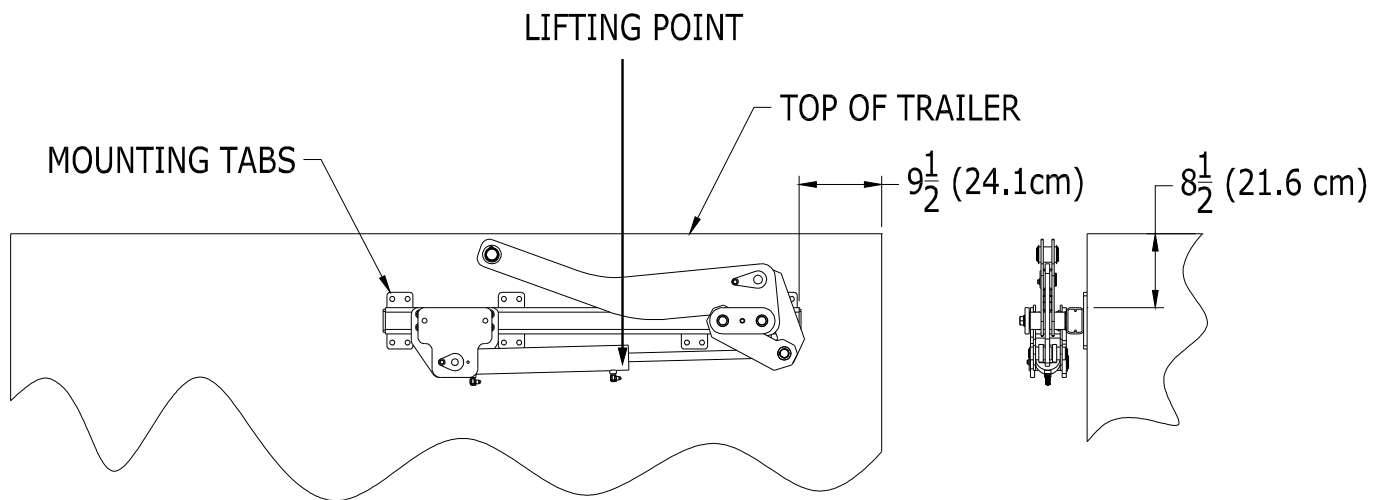

2. DRILL THE MARKED HOLE LOCATIONS TO ACCEPT 1/2" (1.3 cm) GRADE 5 (CLASS 8.8) OR BETTER BOLT (NOT SUPPLIED).
3. POSITION UNIT BACK INTO PLACE, AND SECURE USING 1/2" (1.3 cm) BOLTS MENTIONED IN STEP #2.

NOTE: IF FRONT WALL OF TRAILER IS THIN ALUMINUM OR STEEL, USE SUFFICIENT BACKING PLATES INSIDE OF TRAILER TO SUPPORT THE UNIT.
NOTE: IF TRAILER HAS A ROUND OR 45 deg FRONT CORNER YOU MUST SUPPORT THE FULL ACTUATOR UNIT. BRACE AND GUSSET BEHIND THE UNIT AS NECESSARY.

4. THE PLACEMENT OF THE HINGES IS SHOWN BELOW. IF THE TRAILER IS STEEL THE HINGES CAN BE WELDED INTO PLACE. ON AN ALUMINUM TRAILER USE THE HINGES AS A TEMPLATE, AND MARK THE HOLE LOCATIONS ON THE SIDE AND TOP OF TRAILER TOP RAIL. ON THE SIDE OF THE RAIL DRILL HOLES THROUGH TO THE INSIDE OF TRAILER TO ACCEPT 1/2" (1.3cm) GRADE 5 (CLASS 8.8) OR BETTER BOLTS (NOT SUPPLIED). ON THE TOP RAIL DRILL + TAP 1/2"-13 (M12) OR 1/2"-20 (M12) TO ACCEPT 1/2" (1.3 cm) GRADE 5 (CLASS 8.8) OR BETTER BOLTS (NOT SUPPLIED).

NOTE: TRAILERS WITH A CENTER SUPPORT ABOVE THE TOP RAIL MUST OFFSET THE CENTER HINGES TO EITHER SIDE OF THE SUPPORT.

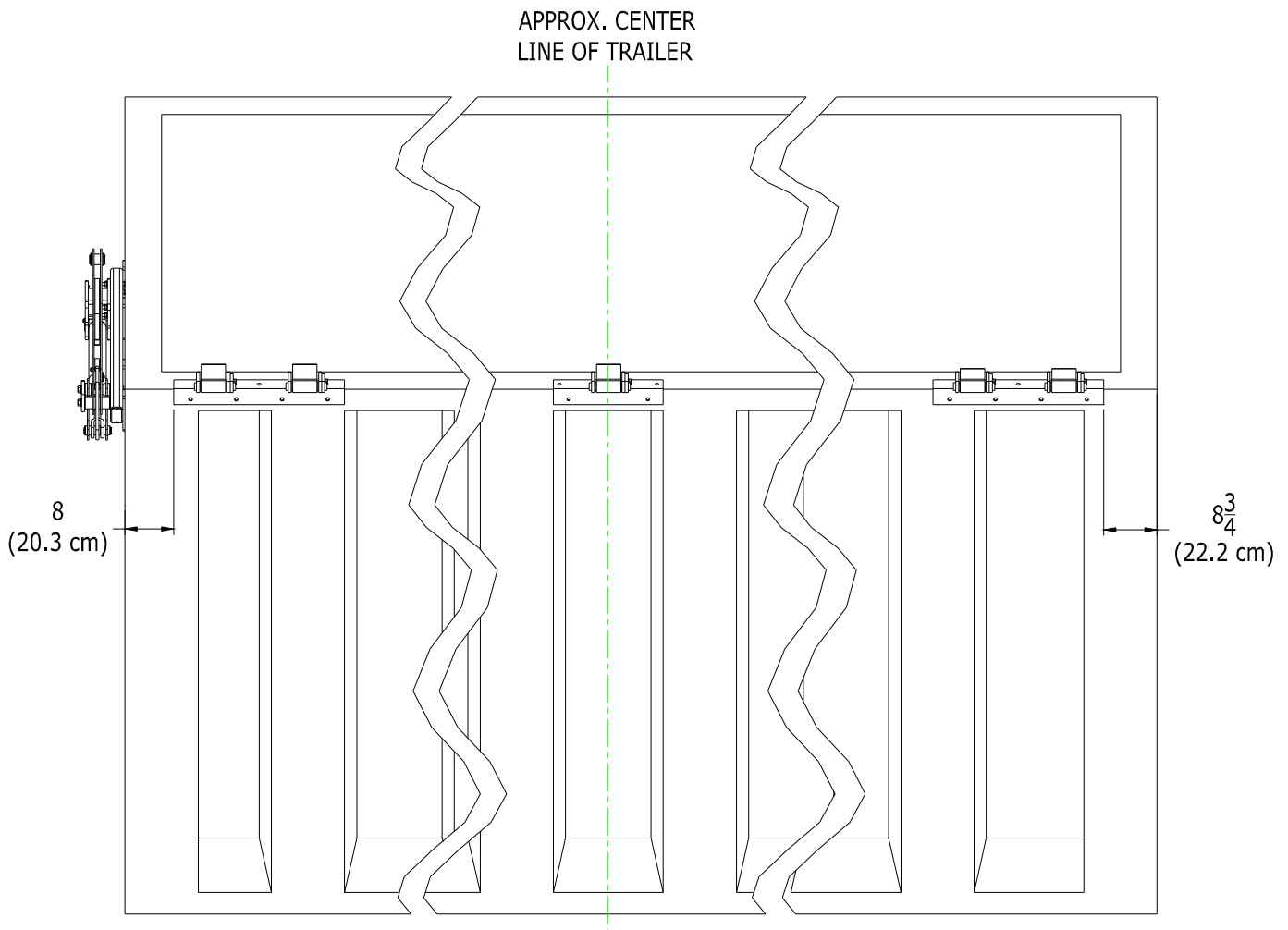

5. BELOW ARE THE LIDS WITH THE CABLE EXTENSIONS SLID INTO PLACE. MEASURE THE TRAILER OUTSIDE WIDTH AT THE FRONT, CENTER AND REAR OF THE TRAILER. USE THESE DIMENSIONS FOR THE APPROPRIATE LID AS SHOWN BELOW, AND WELD EXTENSION TO LID AT THAT WIDTH. NOTE: BOTH FRONT AND REAR LID EXTENSIONS HAVE CABLES ATTACHED TO THEM. THE CENTER EXTENSION DOES NOT.

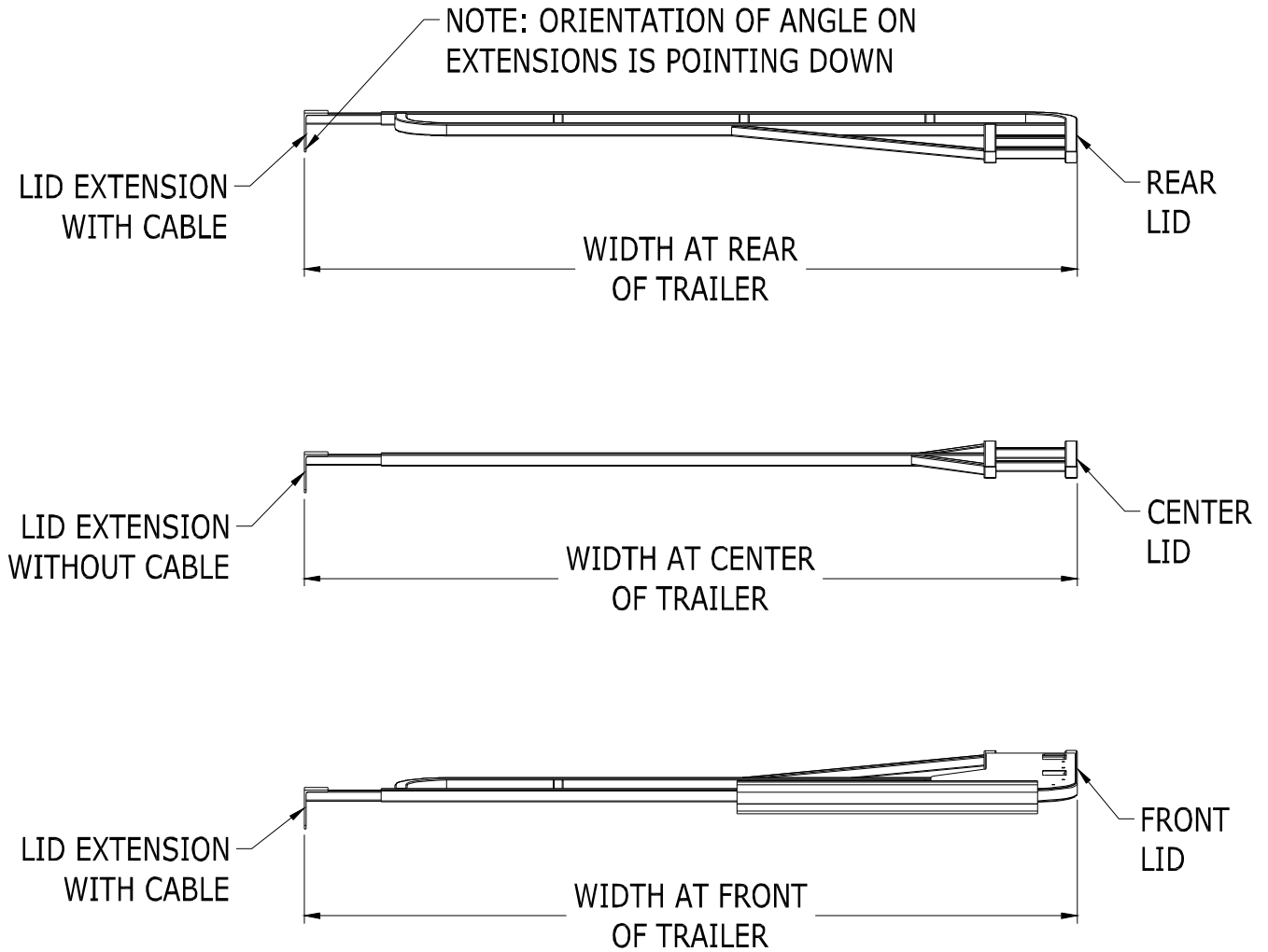

6. INSERT ROLLER AND SHAFT INTO ACTUATOR ARM AS SHOWN

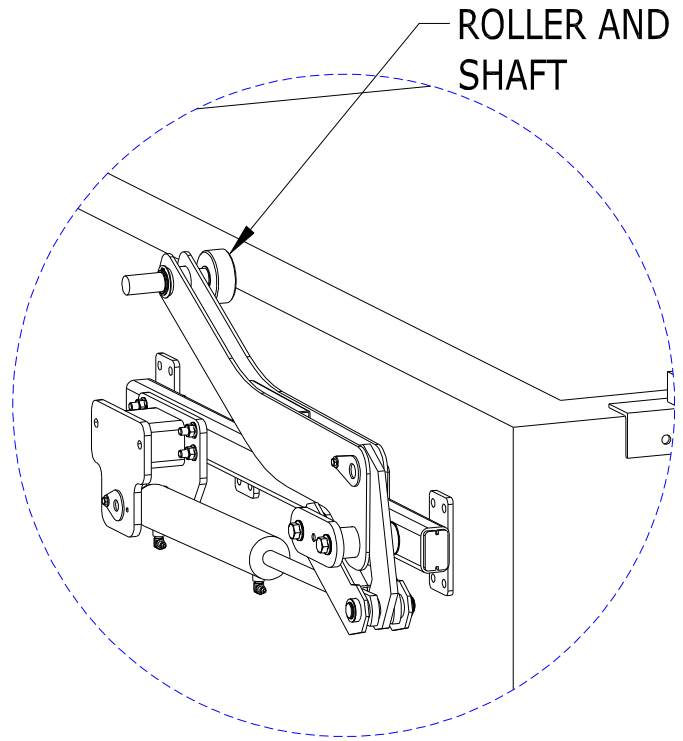

CAUTION!: AT THIS STAGE THE HYDRAULICS MUST BE INSTALLED, AND CYCLED TO ELIMINATE ANY AIR IN THE SYSTEM. FAILURE TO DO THIS COULD RESULT IN PERSONAL INJURY, AND/OR DAMAGE TO THE SYSTEM AT A LATER STAGE.

7. HOLD THE PUMP MOUNT BRACKET IN PLACE AS A TEMPLATE ON THE FRONT OF THE TRAILER JUST BELOW THE ACTUATOR UNIT (APPROX 12", (30.5cm)). MARK THE LOCATION OF THE (4) HOLES, AND DRILL THROUGH TO EXCEPT 3/8 x 1 1/2 (.88cm x 3.81cm) LONG BOLTS PROVIDED. USE WASHERS AND 3/8 (.88cm) LOCK NUTS PROVIDED TO SECURE IN PLACE..



8. PLACE (4) RUBBER BUMPERS IN PLACE AS SHOWN AND SECURE PUMP BY USING 3/8-16 (.88cm) LOCK NUTS AND WASHERS.

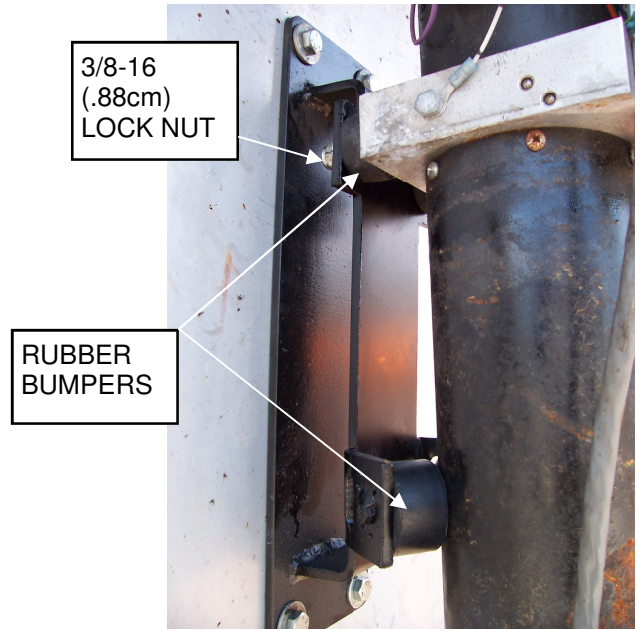

9. SECURE BOTTOM OF PUMP USING LARGE HOSE CLAMP AS SHOWN



10. CONNECT THE (2) HYDRAULIC HOSES (#3320) TO THE PUMP AND CYLINDERS AS SHOWN. USE THE HOSE CLIPS AND SELF DRILLING SCREWS PROVIDED TO ORGANIZE AND SECURE THE HOSES.

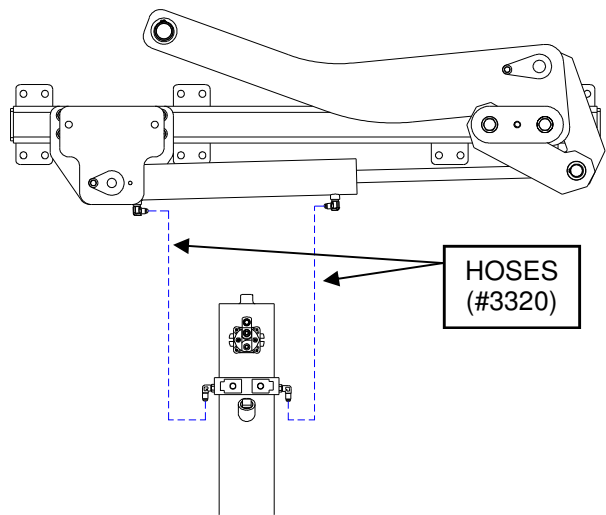

- MOUNT CONTROL SWITCH AS SHOWN, WITH CABLE COMING FROM BOTTOM, USING (2) SELF DRILLING SCREWS PROVIDED.

IMPORTANT: INSTALL THE CONTROL SWITCH IN AN AREA WHERE THE OPERATOR CAN SAFELY OBSERVE AND OPERATE THE SYSTEM.

MOUNT THE QUICK DISCONNECT POWER CABLE NEAR THE CONTROL SWITCH SO THE OPERATOR HAS EASY ACCESS.

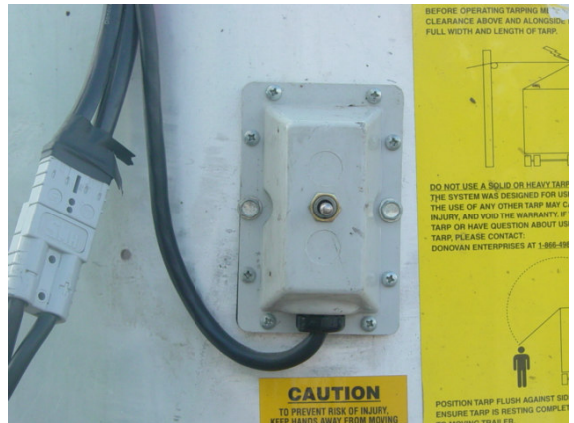

USE THE HOSE CLIPS AND SELF DRILLING SCREWS PROVIDED TO ORGANIZE AND SECURE THE CABLES TO FRONT OF TRUCK.

INSTALL ALL SAFETY STICKERS NEXT TO THE CONTROL SWITCH. SEE PAGE 17 FOR STICKER DESCRIPTION.

REMOVE RED CAP FROM THE FILLER NECK ON PUMP, AND FILL PUMP WITH APPROXIMATELY (3) QUARTS (2.83 L) OF DEXTRON AUTOMATIC TRANSMISSION FLUID. REPLACE RED CAP WITH BLACK BREATHER CAP.

NOTE: UNDER NORMAL OPERATING CONDITIONS THE FLUID IN THE HYDRAULIC PUMP WILL LAST THE LIFE OF THE PUMP. IN EXTREME DIRTY OR WET CONDITIONS, CHECK THE FLUID EVERY FOUR TO SIX MONTHS, AND CHANGE IF NECESSARY.

- CONNECT A 12V POWER SUPPLY TO THE QUICK DISCONNECT POWER CABLE, AND CYCLE THE CYLINDER (10) TIMES TO REMOVE ANY AIR IN THE SYSTEM.

FAILURE TO DO THIS COULD RESULT IN PERSONAL INJURY, AND/OR DAMAGE TO THE SYSTEM AT A LATER STAGE.

- SLIDE FRONT LID ROLLER TRACK OVER THE ROLLER, AND ATTACH THE LID TO THE HINGES USING 1/2" x 3" (1.3cm x 7.6cm) BOLTS, LOCK NUTS AND WASHERS PROVIDED. THE FRONT LID AND HINGES (SHOWN) USE (4) BOLTS, THE REAR ALSO USE (4) BOLTS, AND THE CENTER LID USES (2) BOLTS.

NOTE: THE FRONT LID WEIGHS 91 lb (41 Kg). USE A OVER HEAD LIFTING DEVICE, AND SLING TO LIFT INTO MOUNTING LOCATION. PLACE SLING AROUND TUBE AT LOCATION MARKED "LIFTING POINT" IN DRAWING BELOW.

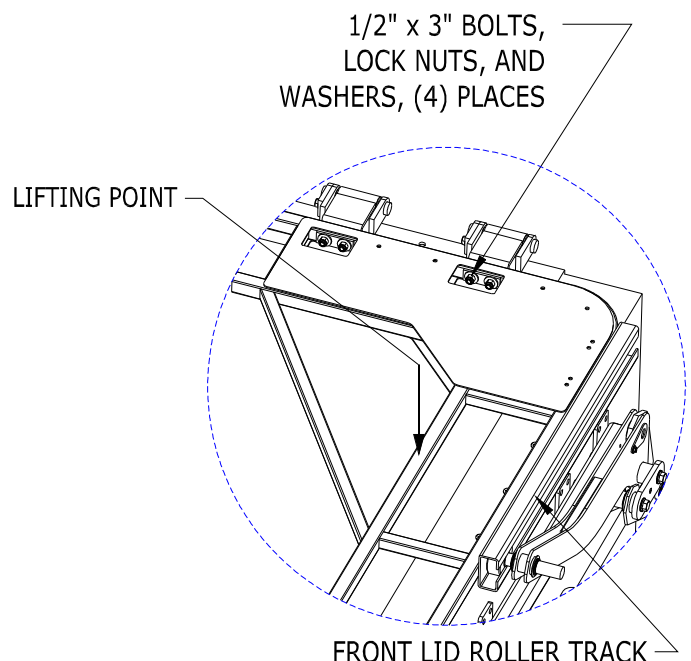

14. MEASURE THE DISTANCE BETWEEN THE LIDS IN THE (2) PLACES SHOWN.

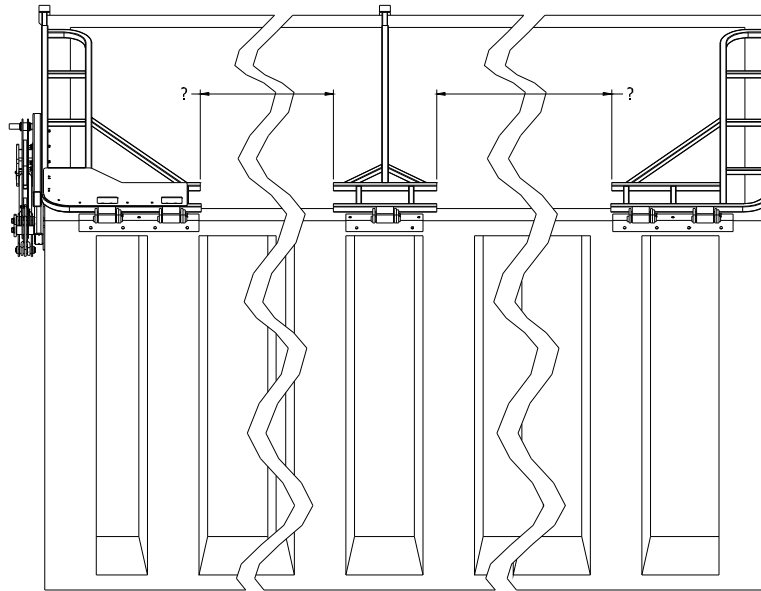

15. ADD 8" (20.3 cm) TO EACH OF THE (2) MEASUREMENTS TAKEN IN STEP #10. THIS WILL BE THE LENGTH OF THE LADDER SECTIONS BETWEEN THE LIDS. WELD THE "H" CONNECTORS AND LADDERS ON THE GROUND AS SHOW BELOW. THE LADDER SECTION MAY NEED TO BE CUT, AND/OR EXTRA "H" CONNECTORS AND LADDERS (SUPPLIED) MAY BE USED TO OBTAIN THE DESIRED LENGTH.

NOTE: WHEN LADDER SECTIONS ARE WELDED TOGETHER THEY CAN WEIGH AS MUCH AS 70 lb (31.8 Kg). USE A OVER HEAD LIFTING DEVICE AND SLING TO LIFT INTO PLACE. LOCATE SLING AT THE CENTER OF THE WELDED LADDER SECTIONS TO EVENLY DISTRIBUTE THE WEIGHT.

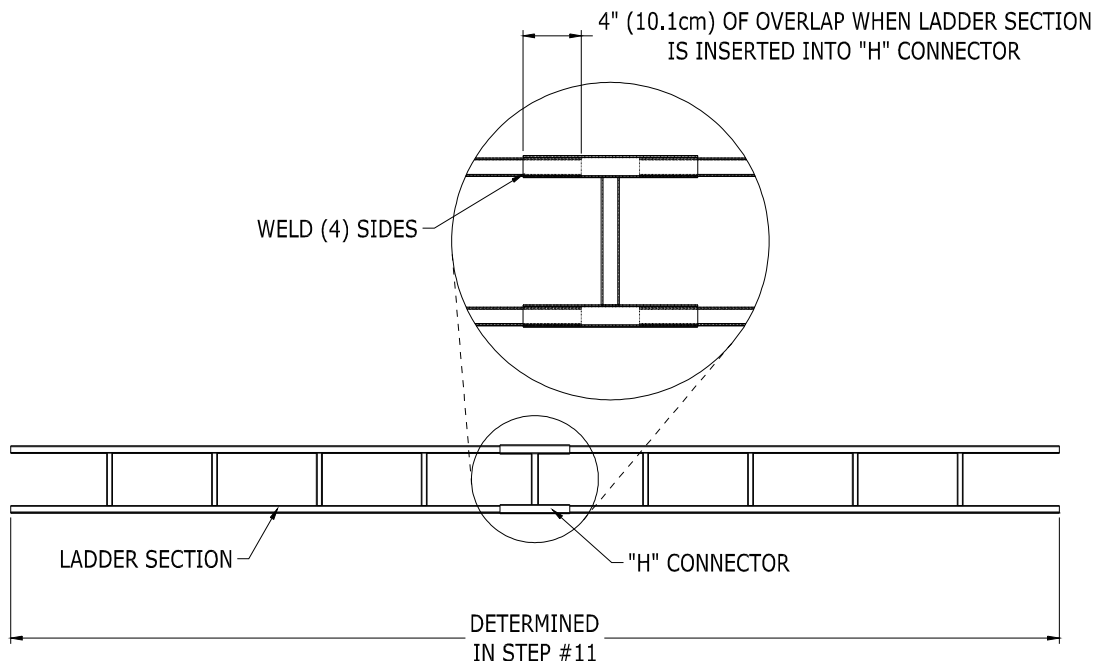

16. RAISE THE APPROPRIATE LADDER SECTIONS INTO PLACE, AND SLIDE 4" (10.1cm) OF THE LADDER INTO EACH LID, AND WELD AROUND ALL FOUR SIDES OF EACH LADDER TO THE LID.

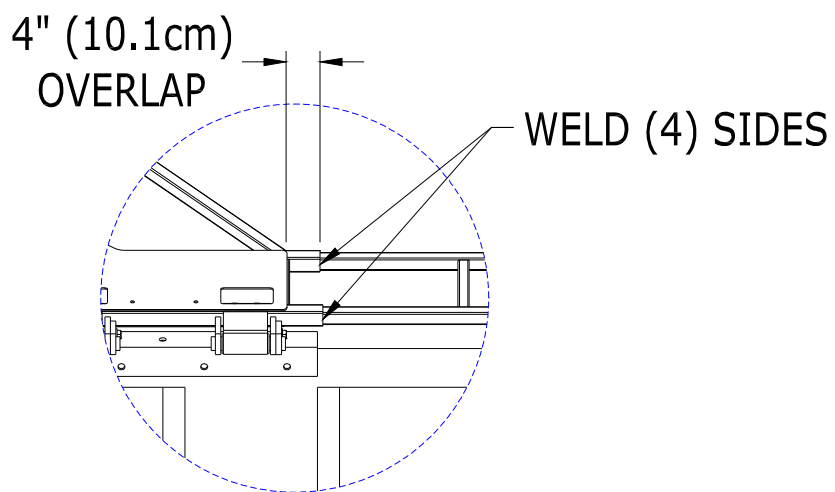

17. OPEN THE SYSTEM SO THE LID LAYS FLAT ON THE SIDE OF THE TRAILER TO INSTALL THE TARP CABLES AND TARP.

THERE WILL BE TWO 30' LENGTH OF CABLE WITH TURNBUCKLES ATTACHED. EXTEND THE TURNBUCKLES SO THEY ARE FULLY EXTENDED. ATTACH EACH TURNBUCKLE TO THE CENTER LID AS SHOWN.

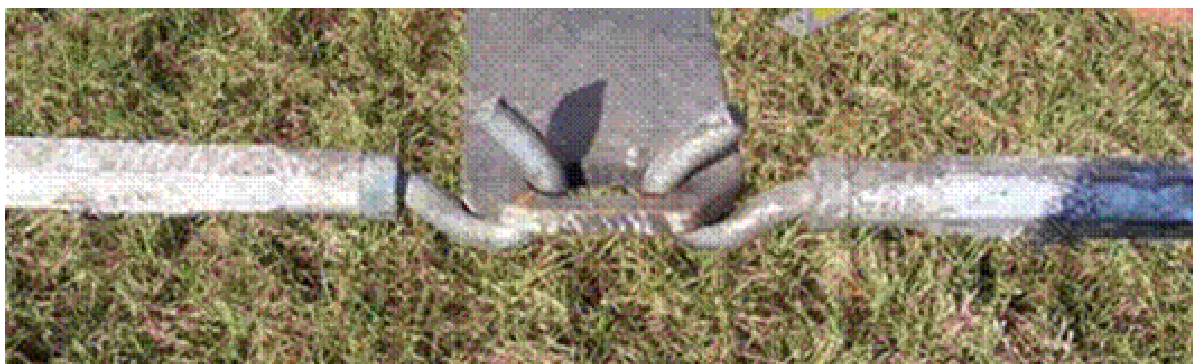

18. ATTACH ONE CABLE FROM THE CENTER LID TO THE FRONT LID EXTENSION. ATTACH THE OTHER CABLE FROM THE CENTER LID TO THE REAR LID EXTENSION. ATTACH THESE CABLES TO THE FRONT AND REAR EXTENSIONS USING ONE 3/16" THIMBLE AND TWO 3/16" CABLE NUTS PER END. PULL CABLES AS TIGHT AS POSSIBLE BY HAND AND SECURE THE CABLE NUTS (TIGHTEN TO APPROX. 30FT.-LB (40.6NM))

19. TIGHTEN BOTH TURNBUCKLES UNTIL THE CABLES ARE TAUGHT. **NOTE: DO NOT OVER TIGHTEN THE TURNBUCKLES**, THIS COULD CAUSE EXCESS STRESS ON THE LIDS AND HINGES. TIGHTEN THE JAM NUTS ON EACH TURNBUCKLE TO PREVENT LOOSENING (USE OF A LIQUID THREAD LOCKER IS RECOMMENDED ON THE JAM NUTS).

20. ATTACH THE TARP STARTING AT THE FRONT LID WORKING YOUR WAY TO THE BACK ON THE CABLE ONLY USING A ZIP-TIE AT EVERY 12" to 18" (30.5cm to 45.7cm) AS SHOWN. (TARP IS SHOWN INSTALLED)



21. TILT THE LID TO THE POSITION SHOWN AND ATTACH THE TARP, STARTING FROM THE FRONT, TO THE SYSTEMS LADDER SIDE USING ZIP TIES EVERY 12" to 18" (30.5cm to 45.7cm).



22. ATTACH THE TARP ALONG THE FRONT LID WITH ZIP TIES. USE THE HOLES AND CHAIN LINKS WHERE PROVIDED.

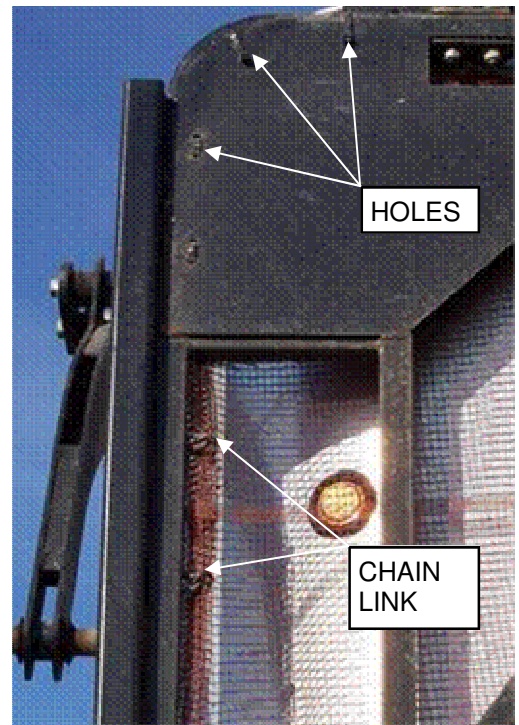

23. FOR TRAILERS THAT ARE SHORTER THAN THE TARP LENGTH, CUT THE TARP AT THE BACK OF THE TRAILER, BUT LEAVE APPROX. 6" to 8" (15.2cm to 20.3cm) EXTRA MATERIAL. FOLD OVER THE EXCESS MATERIAL, AND ZIP TIE ALONG REAR LID.

TIP: IF THERE IS A GAP BETWEEN THE REAR LID, AND THE TRAILER REAR DOOR, DO NOT CUT THE EXCESS TARP MATERIAL. ROLL THE EXCESS TARP MATERIAL UP AND ZIP-TIE IT TO THE REAR LID TO HELP COVER THE GAP.

NOTE: 2" (5cm) WIDE SPLICING TAPE IS SUPPLIED, AND CAN BE USED TO PROTECT THE TARP BY WRAPPING A SMALL LENGTH AROUND ANY SHARP POINTS ON THE SYSTEM.

25. INSTALL THE WIND DEFLECTOR OVER THE HYDRAULIC UNIT USING (6) STAINLESS STEEL BUTTON HEAD BOLTS, (3) AT 3" (7.6cm) AND (3) AT 2" (5cm). USE THE LARGE WIND DEFLECTOR BRACKET ON THE LEFT, AND THE SMALL WIND DEFLECTOR BRACKET ON THE RIGHT AS SHOWN BELOW (OPPOSITE IF THE INSTALL IS ON THE PASSENGER SIDE). USE THE LOC-TITE PROVIDED ON THE (1) MIDDLE BOLT SHOWN, AND LOCK NUTS ON THE (5) REMAINING BOLTS.

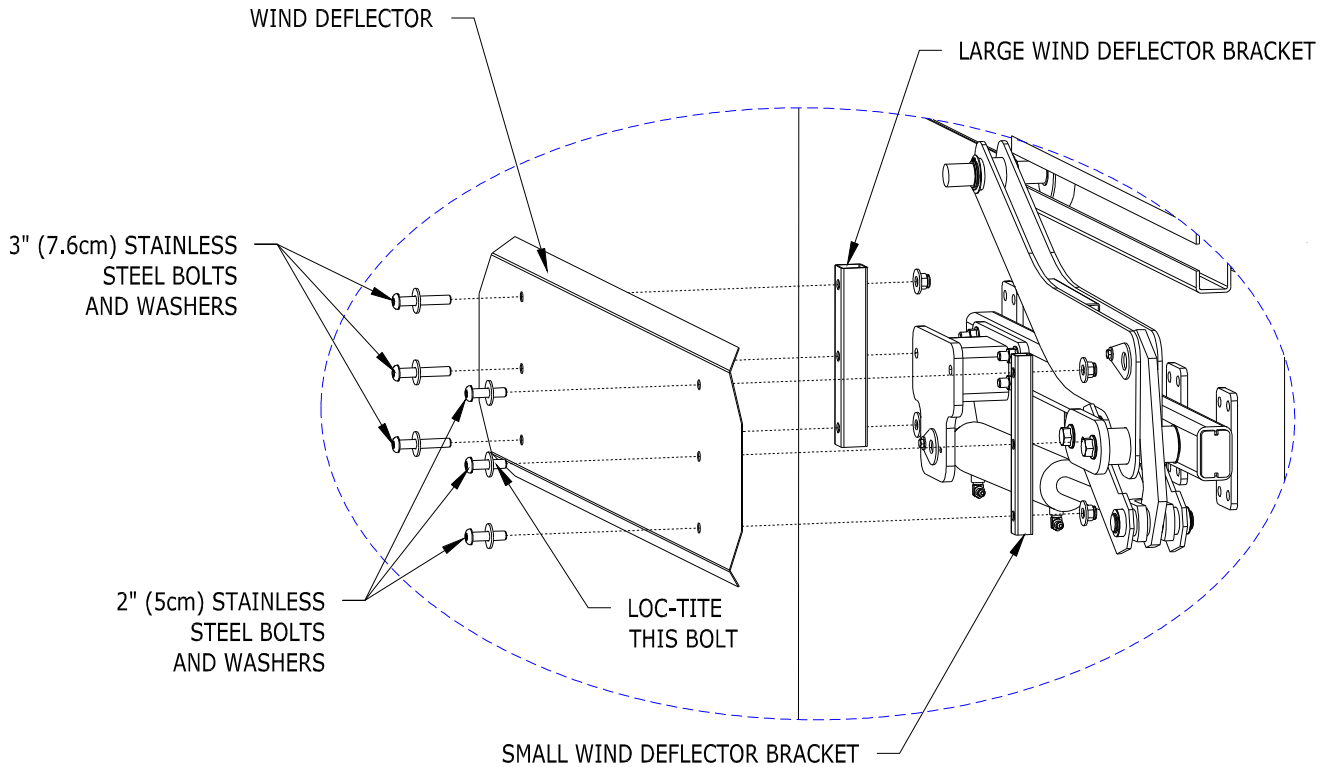

PERIODIC MAINTENANCE and INSPECTION:

-Daily:

1. Check mechanism for any damage or cracks.
2. Check tarpaulin for excessive wear and tear.
3. If equipped, check electrical cables for insulation damage.
4. Check hoses and fittings for cracks and leaks.
5. Check tarpaulin cable and adjust if loose.

- Weekly:

1. Check cylinders for leaks or excessive wear.
2. Check tightness of the fasteners.
3. Check hinges for excessive wear.
4. Check hydraulic actuator for any cracks, damage or excessive wear.
5. If equipped, check the hydraulic fluid level in hydraulic pump.

- Monthly:

1. Operate system to verify proper safe operation.
2. Check roller trolley and bearing for damage in front lid.

OPERATING INSTRUCTIONS

CAUTION: BEFORE OPERATING THIS OR ANY TARDER, CHECK YOUR SURROUNDINGS. LOOK FOR OVERHEAD POWER LINES, TREE LIMBS, ETC.. DO NOT OPERATE SYSTEM WHEN DANGER OF LIGHTNING STRIKE IS PRESENT.

CAUTION: When servicing or repairing the Sidewinder II system, disconnect power to the components from the vehicles battery.

NOTE: The noise level is less than 72dB(A)

TO OPEN TARP

PRESS UP ON SWITCH LEVER TO OPEN LID.

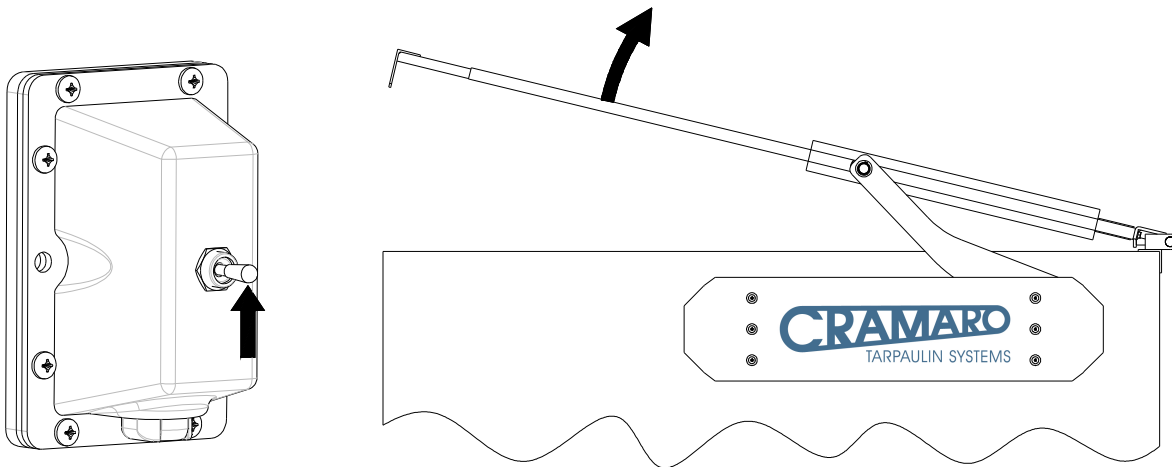

TO CLOSE TARP

PRESS DOWN ON SWITCH LEVER TO CLOSE LID.

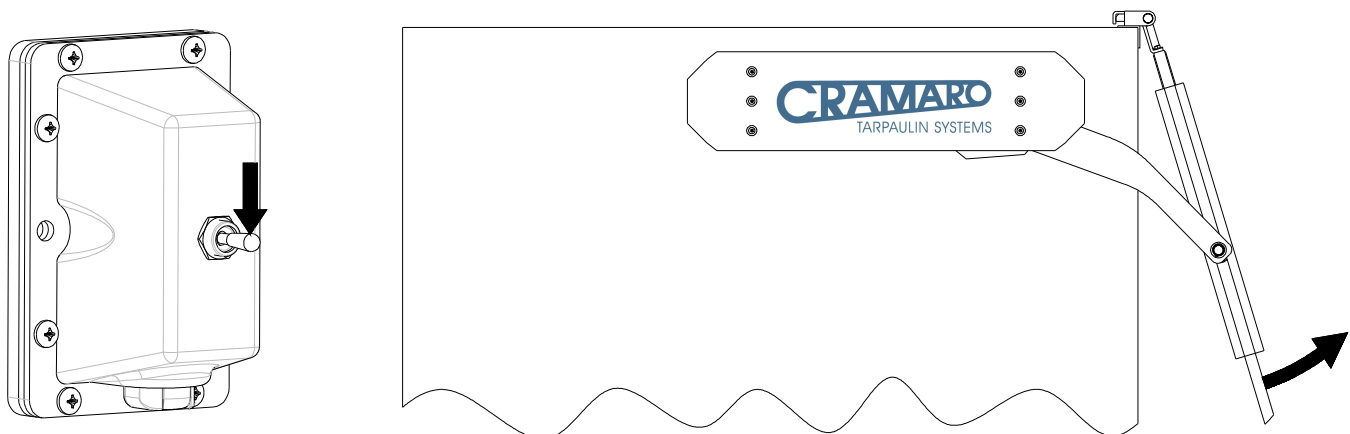

SAFETY STICKERS



CAUTION

BEFORE OPERATING TARPING MECHANISM, ENSURE ADEQUATE CLEARANCE ABOVE AND ALONGSIDE TRAILER. ACCOUNT FOR FULL WIDTH AND LENGTH OF TARP.

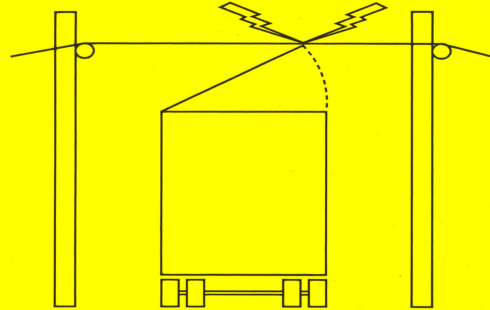

DO NOT USE A SOLID OR HEAVY TARP ON THE SIDEWINDER. THE SYSTEM WAS DESIGNED FOR USE WITH THE TARP SUPPLIED. THE USE OF ANY OTHER TARP MAY CAUSE SYSTEM FAILURE, INJURY, AND VOID THE WARRANTY. IF YOU NEED A REPLACEMENT TARP OR HAVE QUESTION ABOUT USING A DIFFERENT STYLE TARP, PLEASE CONTACT:
DONOVAN ENTERPRISES AT [1-866-498-6937](tel:1-866-498-6937) OR [1-800-327-8287](tel:1-800-327-8287)

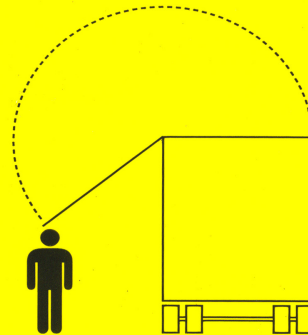

POSITION TARP FLUSH AGAINST SIDE OF TRAILER BEFORE LOADING. ENSURE TARP IS RESTING COMPLETELY ON TOP OF TRAILER PRIOR TO MOVING TRAILER.

CAUTION

BEFORE OPERATING TARP SYSTEM, ENSURE AREA ABOVE AND BESIDE VEHICLE IS CLEAR OF ELECTRICAL LINES OR OTHER OBSTRUCTIONS. ENSURE ADEQUATE LIGHTING WHENEVER OPERATING YOUR TARP COVERING SYSTEM.

CAUTION

TO PREVENT RISK OF INJURY, KEEP HANDS AWAY FROM MOVING PARTS WHILE TARP SYSTEM IS IN OPERATION.

CAUTION

DO NOT MOVE VEHICLE WITH TARP SYSTEM IN RAISED POSITION.

#4663

LIFT-N-LOAD WET KIT

1. CONNECT "T" FITTING TO HYDRAULIC RETURN LINE.
2. CONNECT PRIORITY FLOW CONTROL VALVE TO HYDRAULIC SUPPLY LINE.
3. ATTACH HANDLE TO FRONT OF TRAILER IN A SUITABLE LOCATION FOR OPERATION.
4. HOOK UP 9' HYDRAULIC HOSE TO THE TRAILER'S CENTER-MOST HYDRAULIC CYLINDER FITTING.
5. HOOK UP 8' HYDRAULIC HOSE TO THE TRAILER'S OUTER-MOST HYDRAULIC CYLINDER FITTING.
6. WITH HYDRAULICS BEING SUPPLIED TO PRIORITY FLOW CONTROL VALVE, CYCLE HAND VALVE BACK AND FORTH 3 TO 4 TIMES TO PURGE ANY AIR FROM HYDRAULIC LINES.

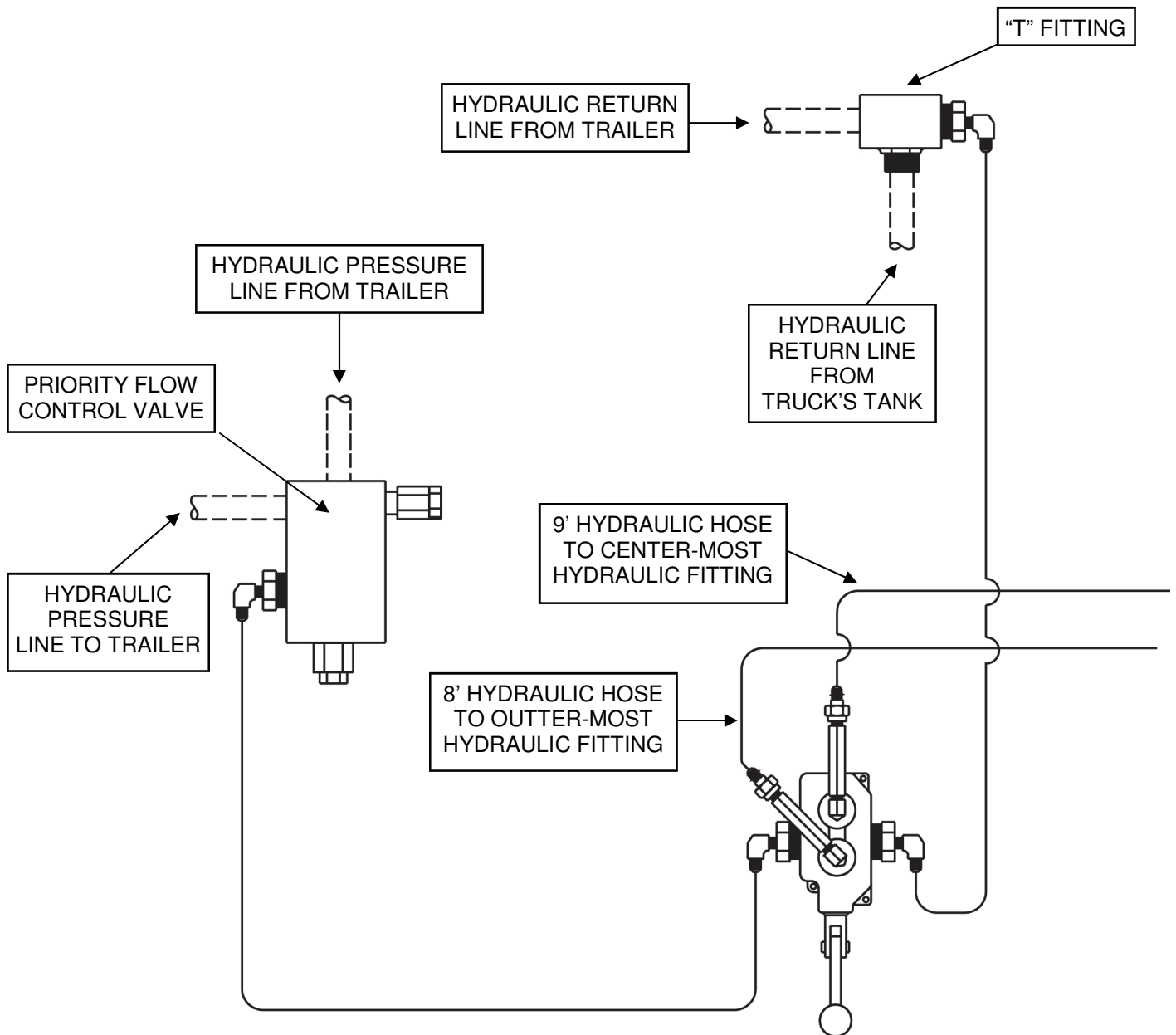

LIFT-N-LOAD WET KIT PARTS BREAKDOWN

